



**EUROTHERM
DRIVES**

HTTL Speed Feedback Technology Box

Technical Manual

HA467152U001 Issue 2

Compatible with Version 5.x Software

© Copyright Eurotherm Drives Limited 1999

All rights strictly reserved. No part of this document may be stored in a retrieval system, or transmitted in any form or by any means to persons not employed by a Eurotherm group company without written permission from Eurotherm Drives Ltd.

Although every effort has been taken to ensure the accuracy of this document it may be necessary, without notice, to make amendments or correct omissions. Eurotherm Drives cannot accept responsibility for damage, injury, or expenses resulting therefrom.

Safety Information



Please read this information **BEFORE** installing the equipment.

Intended Users

This manual is to be made available to all persons who are required to install, configure or service equipment described herein, or any other associated operation.

The information given is intended to highlight safety issues, and to enable the user to obtain maximum benefit from the equipment.

Application Area

The equipment described is intended for industrial motor speed control utilising AC/DC induction or synchronous machines.

Personnel

Installation, operation and maintenance of the equipment should be carried out by qualified personnel. A qualified person is someone who is technically competent and familiar with all safety information and established safety practices; with the installation process, operation and maintenance of this equipment; and with all the hazards involved.

REFER TO YOUR MAIN PRODUCT MANUAL FOR SPECIFIC SAFETY INFORMATION ABOUT THE DEVICE YOU ARE CONTROLLING

Contents

Contents

Page

HTTL SPEED FEEDBACK TECHNOLOGY BOX	1
Description	1
• Features	1
• Used On	1
• Specifications.....	1
Recommended Spare Parts	1
Installation	2
Wiring the System	2
DIP Switch Settings.....	3
Terminal Block (TB1) Connections	3
Understanding the LED Indications	4
• Module LED.....	4
• Encoder LED	4
Initial Set-up	5
Configuring the 605C Inverter	5
Eurotherm Drives Approved Encoders	6

HTTL SPEED FEEDBACK TECHNOLOGY BOX

Description

The HTTL Speed Feedback Technology Box option (Part No. 6054/HTTL/00) allows incremental encoders to be connected directly to the motor controller to provide highly accurate speed feedback measurement.

Features

The option has the following features:

- Contains four optically isolated differential inputs on channels A, B, M and H
- Decoding logic to interface the encoder to the microprocessor
- Supplies variable voltage, isolated encoder power supply

Used On

This option can be used on:

- 605C Inverter and larger

Specifications

Maximum Pulse Rate	250kHz
Receiver Current	≤10mA per channel
Input Format	Two differential channels in quadrature, clock/dir or clock only
Differential Input Voltage	3V ±1 or 8V ±1 depending upon DIP switch settings
Encoder Supply	Maximum load = 200mA or 2W, whichever is smaller. Voltage adjustable 10-20V by firmware
Terminal Wire Size (maximum)	16 AWG
Terminal Tightening Torque	0.4Nm (3.5 pound-inches)

Recommended Spare Parts

We recommend that you keep one option as a spare to reduce down-time.

Installation

Wiring the System

WARNING!

Disconnect all sources of power before attempting installation. Injury or death could result from unintended actuation of controlled equipment.

Caution

This option contains ESD (Electrostatic Discharge) sensitive parts. Observe static control precautions when handling, installing and servicing this option.

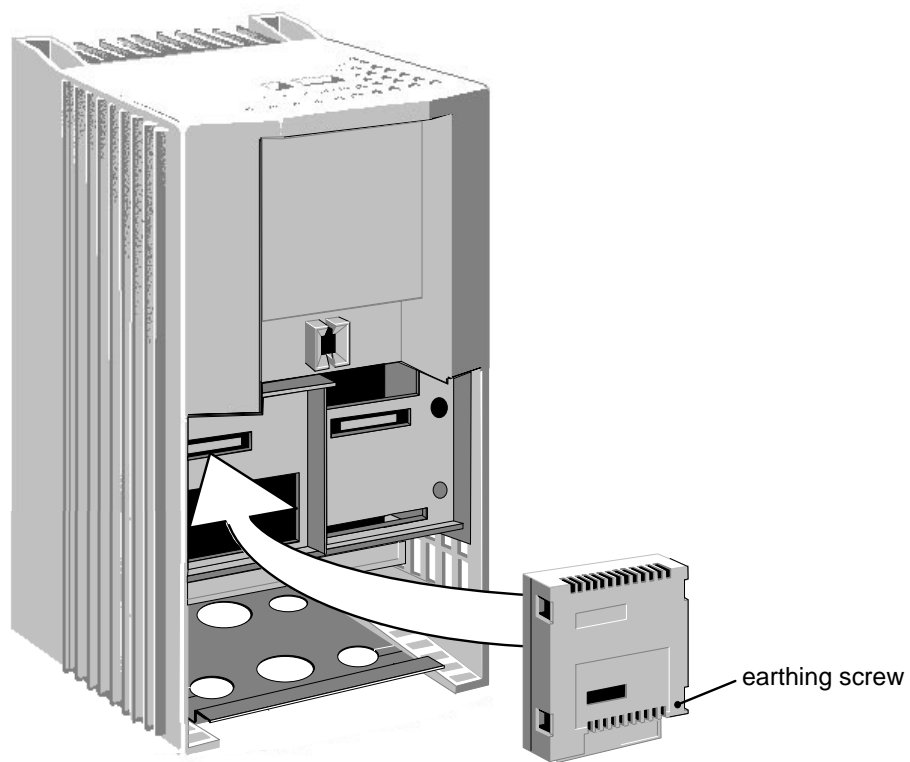

Figure 0-1 Installing the HTTL Speed Feedback Technology Box Option (605C illustrated)

1. Unpack and handle the Option using correct static safety procedures.
2. Remove the inverter terminal cover and securing screws.
3. Carefully plug the Option into the left-hand port (as illustrated above) ensuring correct alignment of the connector and tighten the earthing screw. You can operate the Inverter with the Speed Feedback and/or a Communications Technology Box, but you **cannot** use two options of the same kind.

DIP Switch Settings

The DIP switch can be seen through the casing of the HTTL Speed Feedback Technology Box.

The switch settings control the following inputs:

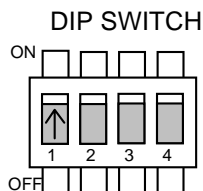

Input Threshold				
Input Threshold				
Switch Number	1	2	3	4
Input Controlled	H	A	B	M
3V±1	On	On	On	On
8V±1	Off	Off	Off	Off

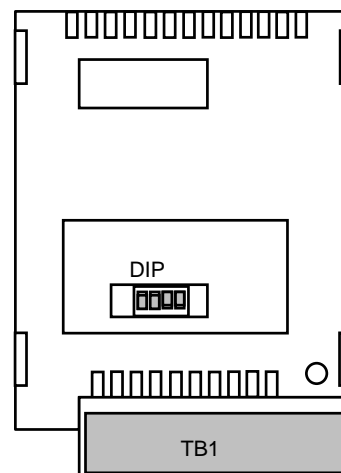

Usually the switches will be set to give a threshold of 3V when using a differential encoder, and to 8V when using a single-ended encoder.

Terminal Block (TB1) Connections

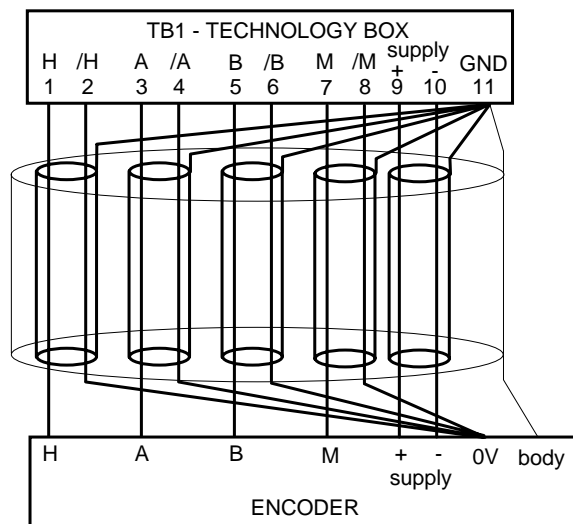

Figure 0-3 Single-Ended Encoder Outputs

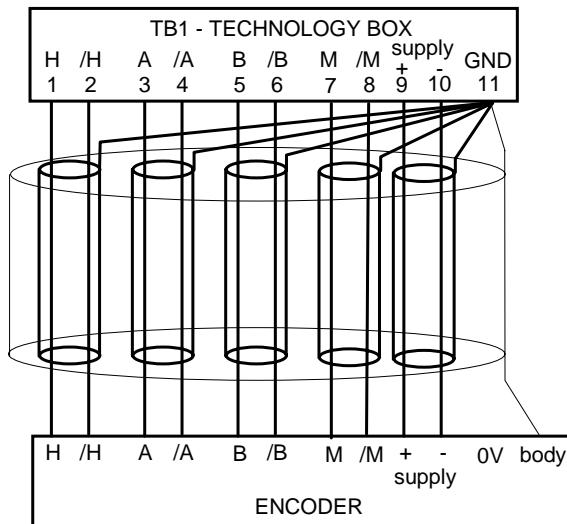

Figure 0-2 Differential Encoder Outputs

For correct operation, A, /A, B and /B **must** be connected as shown. If any is left unconnected, the HTTL speed feedback technology box will not operate.

Note: The M and H inputs are not normally connected - these are for use with future versions of drive software.

M: For connection to the once-per-revolution marker output from the encoder to verify correct operation of the encoder.

H: For where the encoder has provision for a 'health' output.

Take special care wiring the encoders to the option due to the low level of the signals.

All wiring to the HTTL Speed Feedback Technology Box should be made in screened cable. Use cable with an overall screen and a screen over each individual pair. To ensure compliance with the EMC Directive the overall cable screen should be connected to the encoder body and to the terminal block, pin 11.

Recommended cable (pairs individually screened):

Belden equivalent 8777

Eurotherm Drives Part Number CM052666

Understanding the LED Indications

Module LED

In normal operation this LED will be ON. If it fails to come on within 10 seconds after power-up check that the Technology Box is correctly installed.

Encoder LED

This will indicate the status of the Health inputs, pins 1 and 2 on future versions of drive software. If the voltage across pins 1 and 2 exceeds the Minimum Differential Input Voltage set by the DIP switch, the Encoder LED will be ON (pin 1 is positive with respect to pin 2).

Initial Set-up

MMI Menu Map

- 1 SETUP PARAMETERS
- 2 FUNCTION BLOCKS
- 3 INPUTS & OUTPUTS
- 4 ENCODER
 - ENCODER MODE
 - ENCODER LINES
 - ENCODER INVERT
 - ENCODER RESET
 - ENCODER SUPPLY
 - ENCODER SPEED
 - ENCODER SPEED
 - ENCODER SPEED
 - ENCODER POSITION

Configuring the 605C Inverter

Using the Operator Station (MMI) or other suitable PC programming tool, the ENCODER function block requires configuring before the HTTL option can be used.

ConfigEd Lite is Eurotherm Drives' Windows-based block programming software.

ENCODER	
SPEED Hz [568]	0.0 Hz
SPEED RPM [569]	0 n/min
SPEED % [749]	0.00%
POSITION [748]	0
QUADRATURE - [565] MODE	
1000 - [566] LINES	
FALSE - [567] INVERT	
FALSE - [747] RESET	
10.0V - [761] SUPPLY	

Parameter Descriptions

MODE

Range: Enumerated, see below

This must be set to QUADRATURE, CLOCK/DIR or CLOCK.

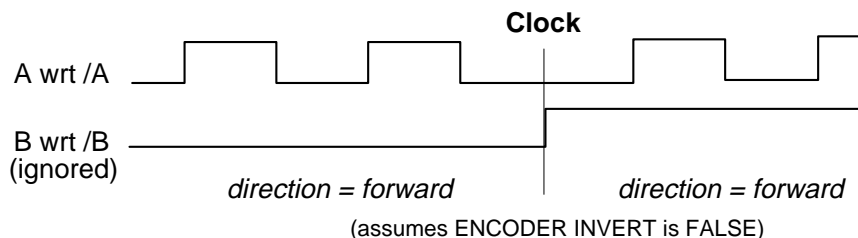
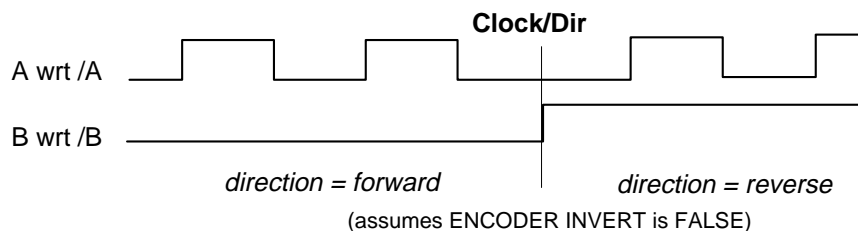
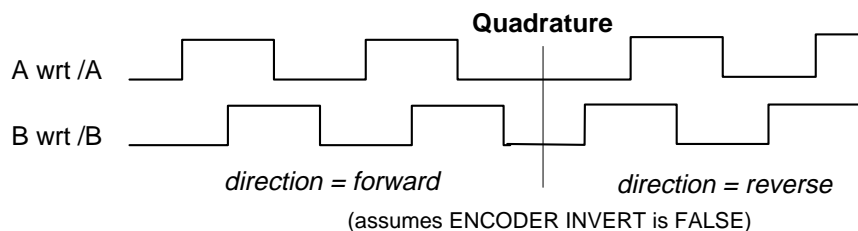

- Enumerated Value : Encoder Mode*
- 0 : QUADRATURE
 - 1 : CLOCK/DIR
 - 2 : CLOCK

LINES*Range: 1 to 10000*

The number of lines must be set to match the type of encoder being used. Incorrect setting of this parameter will result in an erroneous speed measurement.

INVERT*Range: FALSE / TRUE*

When TRUE, changes the sign of the measured speed and the direction of the position count.

RESET*Range: FALSE / TRUE*

When TRUE, the POSITION output is set (and held) at zero.

SUPPLY*Range: 10.0 to 20.0V*

Approximate encoder supply voltage.

SPEED Hz*Range: xxx.xHz*

Speed feedback in Hz.

SPEED RPM*Range: xxxxx n/min*

Speed feedback in RPM.

SPEED %*Range: xxx.xx%*

Speed feedback as a percentage of MAXIMUM SPEED.

POSITION*Range:*

(increments @ 4 x line rate, i.e. 1 revolution = 4000 for a 1000 line encoder)

Number of encoder "counts" from when RESET was set to FALSE. The value will increment or decrement depending on the direction the encoder is rotated. The value will "wrap around" between 32767 and -32768.

Eurotherm Drives Approved Encoders

Recommended Encoder (12mm bore)	Hengstler: Eurotherm Drives Part Number:	RI 58TD//2048ED.371F DD464475U012
Alternative Encoders (20mm bore)	Hengstler: Eurotherm Drives Part Number:	RI 76TD/2048ED-4N20IF DD464475U020

Encoders are available from Hengstler in other accuracies such as 500 lines/rev or 2000 lines/rev to suit the application.

ISS.	MODIFICATION	ECN No.	DATE	DRAWN	CHK'D
1	Initial Issue (HA467152U001)	13059	22/6/99	CM	AFL
2	Differential input voltage corrected pages 1 & 3, earthing screw detail added page 2, approved encoders list updated on page 6.	13702	10/8/99	CM	AFL
FIRST USED ON		MODIFICATION RECORD			
		HTTL Speed Feedback Technology Box			
 EUROTHERM DRIVES		DRAWING NUMBER			SHT. 1
		ZZ467152C001			OF 1

